

UL® US E469421
E209062

**PUTTING POWER AT
YOUR FINGERTIP**

SIGNAGE | CABINETS | CANS



**SMALLER SIZE
FOR EASIER INSTALL**

**20 AMP / 2HP
@ 120-277 VAC**

UL 61058-1 (SWITCH) & UL 879 (SIGN ACCESSORIES)

12" LEAD WIRES (14 AWG, 600V, 105°C)

20 AMP / 2HP @ 120-277 VAC

ON / OFF FACEPLATE

FITS 1/2" PANEL OPENING

INTERNAL TOGGLE SEAL

SILICONE BOOT

EXAMPLE APPLICATION

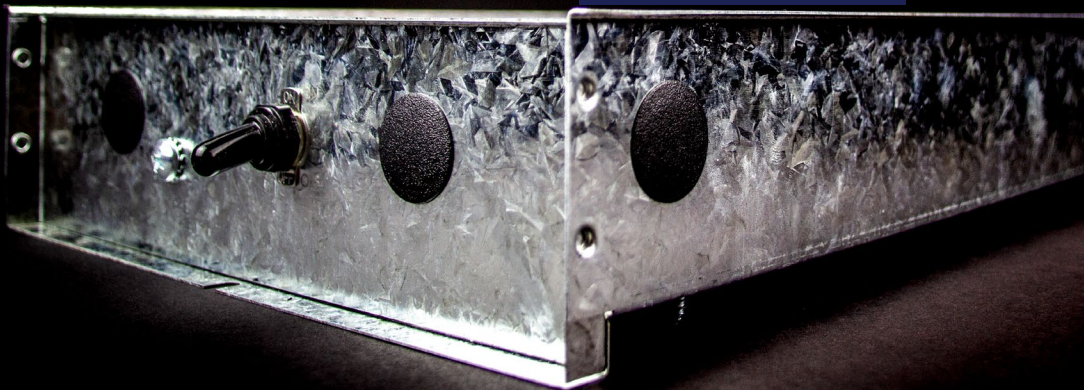

**ASK ABOUT OUR
SWITCH SAFETY
LOCKING PLATE**



**PART #38146
CATALOG #SWSLP**

**NOTE* PER UL48, 20 AMP VAC RATED SWITCHES ARE LIMITED
TO A TOTAL TRANSFORMER LOAD OF 10 AMPS.**

DESCRIPTION	FRANCE PART #	WESTRIM CATALOG #	PACKAGING
SIGN SWITCH W/BOOT, 20 AMP (25)	38057-01	SW20A2HP	25 PER BOX / 20 BOXES PER CASE

ASK YOUR DISTRIBUTOR OR OUR REPRESENTATIVE FOR MORE INFORMATION



SFEG.com/FRANCE
2268 Fairview Blvd.
Fairview, TN 37062
sales@francelighting.com
800.793.4793



U.S. & CANADA REPRESENTATIVES

SCOTT CUTCHER
Central & Eastern U. S. | Eastern Canada

CALVIN ROLLYSON
Western U. S. | Western Canada

EMAIL: SALES@KORVISUALGROUP.COM | PHONE: (615)-900-0966

INSTALLATION INSTRUCTIONS

1. Drill or punch 1/2" hole through mounting surface. De-burr.
2. Remove one nut and "on / off" plate, leaving one nut and lock-washer on switch.
3. With switch in mounting hole, check that barrel extends 3 to 4 threads beyond face of mounting surface.
4. Adjust nut still on switch to obtain this distance.
5. Place switch in mounting hole.
6. Use a wrench to hold rear nut while tightening the nut on the front.
7. For dry locations, slide "on / off" plate over barrel, followed by nut, and tighten.
8. For wet / damp locations, slip boot over toggle and tighten to mounting surface.
9. For "on / off" indication when using boot, use decals provided.

UL[®] **US**
E469421
E209062

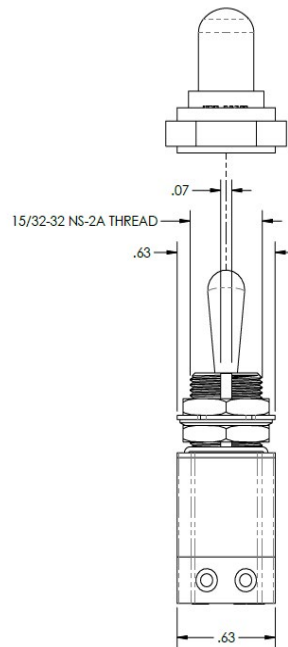
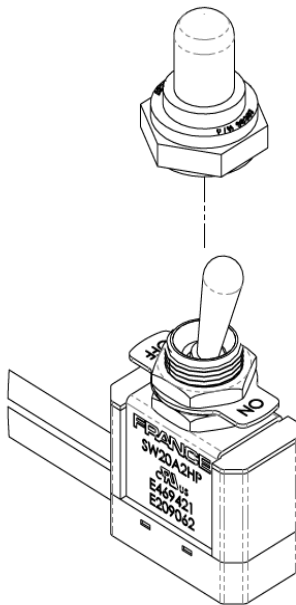
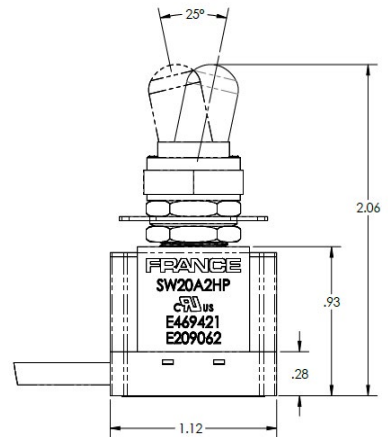
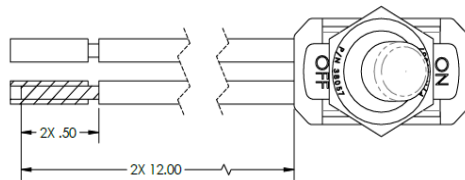

PRODUCT COMPARISON

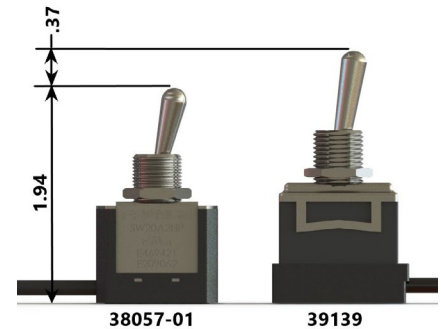

NEW SMALLER FOOTPRINT

PRODUCT SPECIFICATIONS

Contact SFE Customer Service at 800.793.4793

2268 Fairview Blvd., Fairview, TN 37062